

Moline Laminators



Reliable and accurate dough sheet lamination in one compact machine.

The Moline portable laminator is designed to produce a layered dough for products such as puffed pastry, Danish, croissants, pie and pizza crusts. Lamination also equalizes cell structure in the dough providing improved product weight control, overall product quality and shelf life. The unit can handle high infeed conveyor speeds and can provide 2 - 8 laminations (4 - 16 layers).

Two reciprocating conveyors layer the dough for final make-up. Conveyor reciprocation is activated by timing belts driven by a motor and gear reducer. Conveyor belt rotation is individually driven by motors and gear reducers.

These units are typically "right angle machines" because the dough is laminated onto a discharge conveyor that runs 90° to the original direction of dough travel. The laminator is mounted on casters for easy removal from the production line and can be replaced with a 90° transfer conveyor when lamination isn't necessary.

The laminator can accommodate systems from 24" - 60" wide. Conveyor speeds are easily adjusted through the production system's operator interface.



Moline Machinery LLC

114 South Central Avenue • Duluth, Minnesota, USA, 55807
218-624-5734 (For after hours service, call 218-590-1987)
www.moline.com • sales@moline.com



Moline Laminators

Belt Direction and Dough Travel

The direction of dough travel is shown at right. With the discharge conveyor running, the infeed conveyor feeds the dough sheet onto the laminator's upper reciprocating conveyor which in turn feeds the dough onto the lower reciprocating conveyor. From there, the dough is then folded onto the production system's discharge conveyor which runs 90° to the original direction of dough travel.

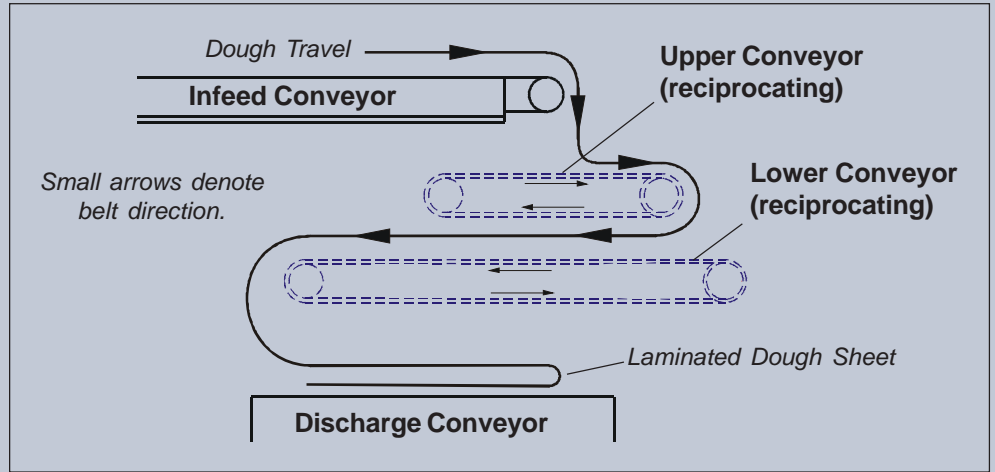

Direction of Dough Travel (side view of laminator)

Specifications

Construction:

Stainless steel construction with precision machined components. Conveyor belting is interlocking plastic.

Guards and Covers:

Safety interlocked guards prevent access during operation, but provide easy access to components for inspection, sanitation and maintenance when the machine is shut down.

Control Functions:

Since the laminator is integrated with the production system, conveyor speeds are easily adjusted through the production system's operator interface.

Proximity sensors provide adjustment for conveyor travel (which determines the width of the laminated dough

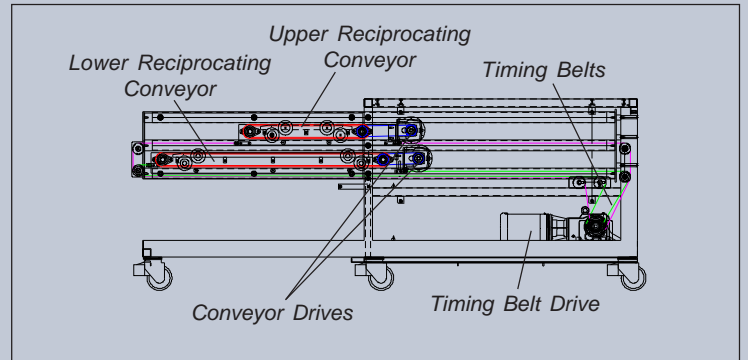

Laminator (side view)

sheet) and for where the dough sheet lands on the discharge conveyor.

Sanitation:

Designed for easy sanitation. Meets or exceeds USDA standards. Sealed electrical components, standoff mounting and continuous welds are among the features that permit direct, high pressure washdown sanitation.

Electrical Specifications:

Standard Electrical Requirements: 480 Volt / 60 Hertz / 3 Phase (other options are available).

Drive System:

Standard: Two 1 hp, 1725 rpm drive motors, and gear reducers, for reciprocating conveyors. One servo drive motor and gear reducer for timing belts.

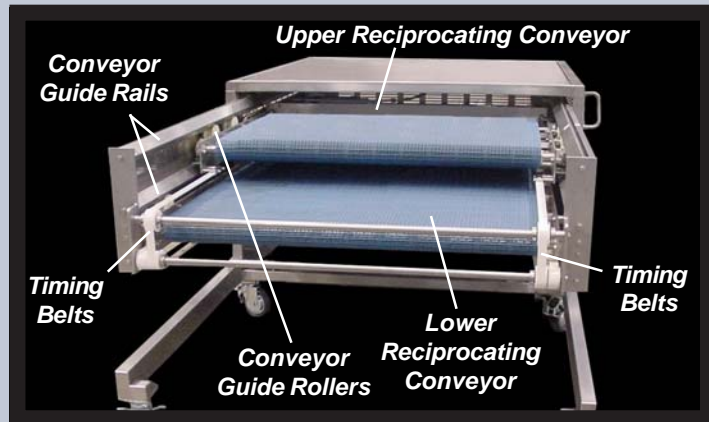

Reciprocating Conveyors and Components