

# Frying Equipment for Donuts and Sweet Goods



**Combining cutting edge technology with efficient sanitation for continuous high-volume production of donuts and sweet goods.**

*Moline industrial frying systems are fully automated, BISSC certified systems designed to suit a wide range of continuous production requirements. System components include gas or electric fryers, cake and yeast-raised product depositors, proofers, conveyors, transpositors, glazing and icing systems, cooling conveyors and sugaring machines.*

*Production capacities are the highest in the industry, ranging from 400 to 4500 dozen per hour.*

*The industrial design of these systems is renowned for durability, reliability and efficiency. Controls are centrally*

*located and easy to use for efficient and consistent production.*

*Moline also provides dependable service "after the sale". Qualified factory-trained technicians provide on-site supervision as the equipment is uncrated, positioned and assembled. The modular design assures fast and precise installation. Mechanical settings are adjusted, product testing is conducted along with operator training to fine tune production methods. Our commitment to safety, reliability and value has made us a leader in baking equipment for well over half a century. Call our Customer Service Department for more information.*



*The DonutKing Depositor/Gas Fryer combination shown above is only one of many system options available from Moline.*

**Moline Frying Systems are custom designed to provide durability, low maintenance and easy cleanup for maximum production.**



**Moline Machinery LLC**

114 South Central Avenue • Duluth, Minnesota, USA, 55807  
218-624-5734 (For after hours service, call 218-590-1987)  
www.moline.com • sales@moline.com

# General Frying System Features

## General Fryer Features:

- Modular stainless steel exhaust canopy fits directly on the fryer frame - no ceiling supports required.
- Stainless steel main conveyor (surface conveyor) assembly with ball screw lift mechanism is designed to lift the conveyor from the kettle with the touch of a button. Limits are provided to prevent over-travel.
- The variable speed main conveyor drive system allows frying times from 60 to 360 seconds. A pneumatic torque

limiter (easily reset) helps to prevent damage should a jam-up occur.

- Electronic control functions are provided through the operator interface. Electronically synchronized product delivery into the main conveyor flight pockets provides accurate and efficient product placement.

## Fryer In-line Product Turner



The product turner, located at the center of the fryer, includes single-lever control to easily adjust for product size. The optional product positioning air system helps to provide smooth product turnover.

## Beneficial Sanitation Features:

- Sealed kettle frame (no openings to the inside) and sediment sumps for improved sanitation.
- Kettle is constructed entirely of stainless steel. All other components are of stainless steel or noncorrosive metals for thorough sanitation. Crevices and hard-to-clean areas have been eliminated.
- Sanitary adjustable legs.
- Stainless steel shortening holding tank with pump.
- Stainless steel canopy with easily accessed filters.
- Stainless steel exhaust manifolds, easily dismantled for cleaning.

## Optional Equipment:

- Turbulence System (helps to reduce side-to-side temperature differential on wide fryers. Provides improved continuous filter operation, extending operating time between boil-outs).
- Remote Electrical Control Panel (keeps fryer controls and electrical away from fryer for more efficient sanitation).
- UL and CE Approvals.
- Fire Protection System.
- Canopy Lighting System (illuminates fryer operations from under the canopy).
- Canopy Side Shields (provides protection from frying oil).
- Canopy Exhaust Blowers (aids in removing residual vapors).
- Product Flip Conveyor (flips product at fryer discharge).
- Submergers (controls product submersion during frying).
- Product-Positioning Air Systems (helps control product position in the fryer during production).
- Portable Shortening Supply Tank.

## Fryer Control Panels



Articulating Arm Style



Canopy Mounted Style

Several fryer control panel styles are available, each with an easy-to-use operator interface touch screen that includes control buttons and graphs for monitoring fryer temperature. Several control panel locations are available including articulating arm mounted, canopy mounted, kettle mounted and remote mounted.

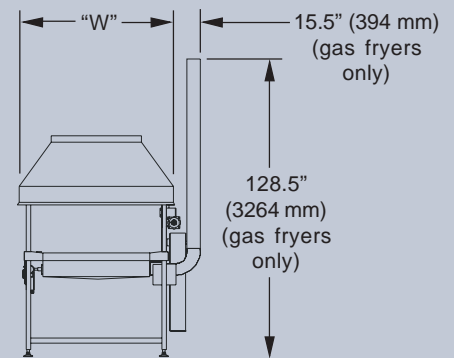
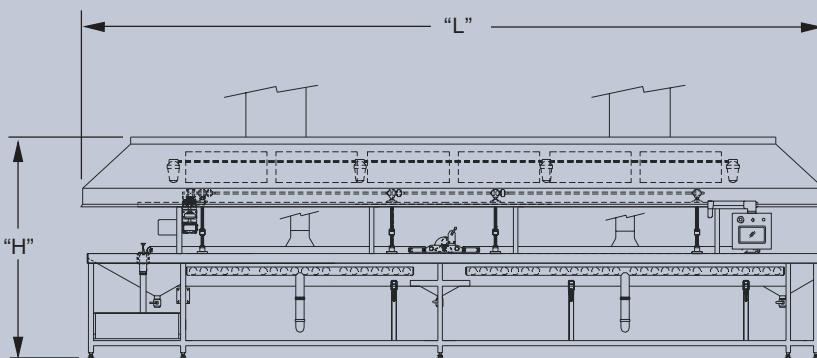

Left hand fryer is shown.

See "Overall Dimensions" in specification tables on the following pages for corresponding sizes to dimensions shown above.

# Gas Frying System Features

## Heating System:

- Flared burner tubes for improved strength and sanitation. The "Cold Zone" design helps to lengthen shortening life.
- Gas fired with independent pre-mixers for maximum safe heat transfer with positive and complete combustion.
- Quick heat recovery by means of pre-mix gas system to accommodate all types and sizes of fried product.

## Electrical System:

- Standard Electrical: 240 or 480 Volt, 60 Hertz, 3 Phase.

## Flue Exhaust:

- Draft inducers interlocked with ignition system.
- Stainless steel flue stacks with barometric dampers.

## Optional Equipment:

- Remote gas plumbing module removes gas plumbing components from washdown area for efficient fryer sanitation.

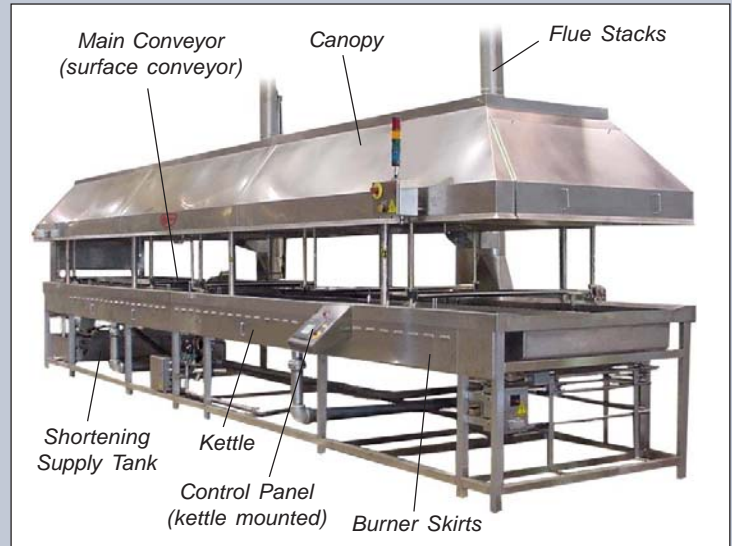

| Fryer Model | Productivity<br>(with 3-3/4" flights and 90 second fry time) | Overall Dimensions<br>(see drawing on page 2 for corresponding dimensions) | Active Flights                |                                |                            | Estimated Shortening Capacity<br>lbs (kg) | Air  | Canopy Exhaust              | Flue Exhaust   |
|-------------|--|--|-------------------------------|--------------------------------|----------------------------|---|--|-----------------------------|--|
|             |  |  | 3-3/4" (95 mm) flight spacing | 4-3/8" (111 mm) flight spacing | 5" (127 mm) flight spacing |   |  |                             |  |
| GF12-8S     | 840 Doz/Hr<br>(8 Cutters)                                    | L = 13' 0" (3962 mm)<br>W = 4' 11" (1499 mm)<br>H = 8' 0" (2438 mm)        | 31.5                          | 27                             | 24                         | 1150 lbs<br>(522 kg)                      | 20 CFM @ 5 to 10 PSI (9.44 Liters/Second @ .69 BAR) Clean, dry, oil free air. Regulated connection to fryer by customer. | 22" (559 mm).<br>1 opening. | Two 10" (254 mm) stacks. Barometric dampers and draft inducers by Moline. Stack installation and connection by customer. |
| GF16-8S     | 1186 Doz/Hr<br>(8 Cutters)                                   | L = 17' 0" (5182 mm)<br>W = 4' 11" (1499 mm)<br>H = 8' 0" (2438 mm)        | 44.5                          | 38                             | 33.5                       | 1627 lbs<br>(738 kg)                      |  | 22" (559 mm). 2 openings.   |  |
| GF16-10S    | 1483 Doz/Hr<br>(10 Cutters)                                  | L = 17' 0" (5182 mm)<br>W = 5' 7" (1702 mm)<br>H = 8' 0" (2438 mm)         | 44.5                          | 38                             | 33.5                       | 1970 lbs<br>(894 kg)                      |  |                             |  |
| GF20-10S    | 1900 Doz/Hr<br>(10 Cutters)                                  | L = 21' 0" (6401 mm)<br>W = 5' 7" (1702 mm)<br>H = 8' 0" (2438 mm)         | 59                            | 49                             | 43                         | 2320 lbs<br>(1052 kg)                     |  |                             |  |
| GF22-8S     | 1693 Doz/Hr<br>(8 Cutters)                                   | L = 23' 0" (7010 mm)<br>W = 4' 11" (1499 mm)<br>H = 8' 0" (2438 mm)        | 63.5                          | 54.5                           | 48                         | 2420 lbs<br>(1098 kg)                     |  |                             |  |
| GF22-10S    | 2117 Doz/Hr<br>(10 Cutters)                                  | L = 23' 0" (7010 mm)<br>W = 5' 7" (1702 mm)<br>H = 8' 0" (2438 mm)         | 63.5                          | 54.5                           | 48                         | 2930 lbs<br>(1329 kg)                     |  |                             |  |
| GF26-10S    | 2500 Doz/Hr<br>(10 Cutters)                                  | L = 26' 6" (8077 mm)<br>W = 5' 7" (1702 mm)<br>H = 8' 0" (2438 mm)         | 75                            | 64                             | 56                         | 3440 lbs<br>(1560 kg)                     |  |                             |  |
| GF28-10S    | 2683 Doz/Hr<br>(10 Cutters)                                  | L = 28' 4" (8637 mm)<br>W = 5' 7" (1702 mm)<br>H = 8' 0" (2438 mm)         | 80.5                          | 69                             | 60.5                       | 4142 lbs<br>(1879 kg)                     |  |                             |  |
| GF30-10S    | 2900 Doz/Hr<br>(10 Cutters)                                  | L = 30' 4" (9246 mm)<br>W = 5' 7" (1702 mm)<br>H = 8' 0" (2438 mm)         | 87                            | 74.5                           | 65                         | 4740 lbs<br>(2150 kg)                     |  |                             |  |
| GF32-10S    | 3116 Doz/Hr<br>(10 Cutters)                                  | L = 32' 4" (9855 mm)<br>W = 5' 7" (1702 mm)<br>H = 8' 0" (2438 mm)         | 93.5                          | 80                             | 70                         | 5340 lbs<br>(2422 kg)                     |  |                             |  |



# Electric Frying System Features

## Heating System:

- The main electrical panel is located at the back of the fryer and supplies power and control to the electric heating elements inside the kettle. The heating element junction boxes, located at the back edge of the kettle, can be raised for sanitation.
- The dual zone electrical heating system is clean, fast, easy to use and provides an even temperature throughout the fryer kettle.

## Electrical System:

- Standard Electrical: 480 Volt, 60 Hertz, 3 Phase.

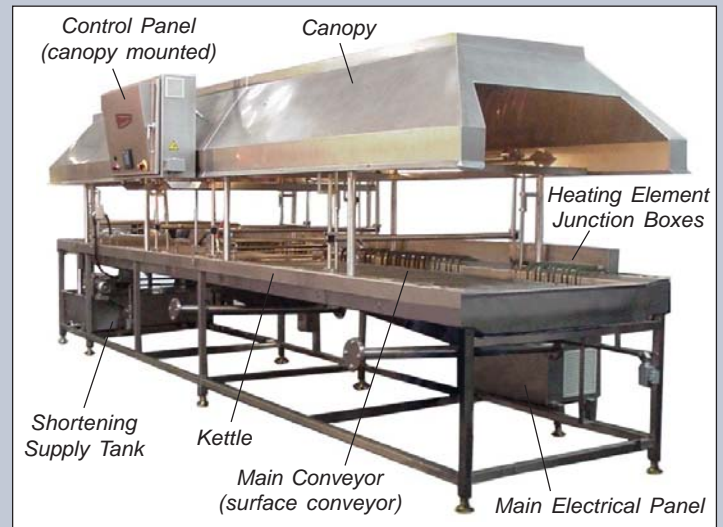

| Fryer Model | Productivity<br>(with 3-3/4" flights and 90 second fry time) | Overall Dimensions<br>(see drawing on page 2 for corresponding dimensions) | Active Flights                |                                |                            | Estimated Shortening Capacity<br>lbs (kg) | Air  | Canopy Exhaust              |  |
|-------------|--|--|-------------------------------|--------------------------------|----------------------------|---|--|-----------------------------|--|
|             |  |  | 3-3/4" (95 mm) flight spacing | 4-3/8" (111 mm) flight spacing | 5" (127 mm) flight spacing |   |  |                             |  |
| EF12-8S     | 840 Doz/Hr<br>(8 Cutters)                                    | L = 13' 0" (3962 mm)<br>W = 4' 11" (1499 mm)<br>H = 8' 0" (2438 mm)        | 31.5                          | 27                             | 24                         | 1000 lbs<br>(499 kg)                      | 20 CFM @ 5 to 10 PSI (9.44 Liters/Second @ .69 BAR) Clean, dry, oil free air. Regulated connection to fryer by customer. | 22" (559 mm).<br>1 opening. | Filters supplied by Moline. Blowers and connections by customer. |
| EF16-8S     | 1186 Doz/Hr<br>(8 Cutters)                                   | L = 17' 0" (5182 mm)<br>W = 4' 11" (1499 mm)<br>H = 8' 0" (2438 mm)        | 44.5                          | 38                             | 33.5                       | 1530 lbs<br>(694 kg)                      |  | 22" (559 mm). 2 openings.   |  |
| EF16-10S    | 1483 Doz/Hr<br>(10 Cutters)                                  | L = 17' 0" (5182 mm)<br>W = 5' 7" (1702 mm)<br>H = 8' 0" (2438 mm)         | 44.5                          | 38                             | 33.5                       | 1850 lbs<br>(839 kg)                      |  |                             |  |
| EF20-10S    | 1900 Doz/Hr<br>(10 Cutters)                                  | L = 21' 0" (6401 mm)<br>W = 5' 7" (1702 mm)<br>H = 8' 0" (2438 mm)         | 59                            | 49                             | 43                         | 2300 lbs<br>(1043 kg)                     |  | 26" (660 mm). 2 openings.   |  |
| EF22-8S     | 1693 Doz/Hr<br>(8 Cutters)                                   | L = 23' 0" (7010 mm)<br>W = 4' 11" (1499 mm)<br>H = 8' 0" (2438 mm)        | 63.5                          | 54.5                           | 48                         | 2410 lbs<br>(1093 kg)                     |  |                             |  |
| EF22-10S    | 2117 Doz/Hr<br>(10 Cutters)                                  | L = 23' 0" (7010 mm)<br>W = 5' 7" (1702 mm)<br>H = 8' 0" (2438 mm)         | 63.5                          | 54.5                           | 48                         | 2560 lbs<br>(1161 kg)                     |  |                             |  |
| EF26-10S    | 2500 Doz/Hr<br>(10 Cutters)                                  | L = 26' 6" (8077 mm)<br>W = 5' 7" (1702 mm)<br>H = 8' 0" (2438 mm)         | 75                            | 64                             | 56                         | 3050 lbs<br>(1384 kg)                     |  |                             |  |
| EF28-10S    | 2683 Doz/Hr<br>(10 Cutters)                                  | L = 28' 4" (8637 mm)<br>W = 5' 7" (1702 mm)<br>H = 8' 0" (2438 mm)         | 80.5                          | 69                             | 60.5                       | 3270 lbs<br>(1483 kg)                     |  |                             |  |
| EF30-10S    | 2900 Doz/Hr<br>(10 Cutters)                                  | L = 30' 4" (9246 mm)<br>W = 5' 7" (1702 mm)<br>H = 8' 0" (2438 mm)         | 87                            | 74.5                           | 65                         | 3500 lbs<br>(1588 kg)                     |  |                             |  |
| EF32-10S    | 3116 Doz/Hr<br>(10 Cutters)                                  | L = 32' 4" (9855 mm)<br>W = 5' 7" (1702 mm)<br>H = 8' 0" (2438 mm)         | 93.5                          | 80                             | 70                         | 3740 lbs<br>(1696 kg)                     |  |                             |  |



# Auxiliary Frying System Equipment

Along with the gas and electric fryers, Moline Frying Systems include many other equipment options as listed below. For more information on these individual

components, call the Moline Customer Service Department at 218-624-5734 or email us at [sales@moline.com](mailto:sales@moline.com).

## Frying System Equipment Options

- DonutKing Cake Donut Depositor
- MD81 Pressure Depositor
- Yeast Raised Pressure Depositor
- Automatic Proofer
- Conveyor Systems
- Glazer Station
- Icer/Glazer Station
- Glazer/Crumber Unit
- SugarKing Sugaring Machine
- Transpositor (for proofer loading)



DonutKing



MD81 Depositor



YRP Depositor



Proofer



Glazer Station



Glazer/Crumber Unit



SugarKing



Transpositor

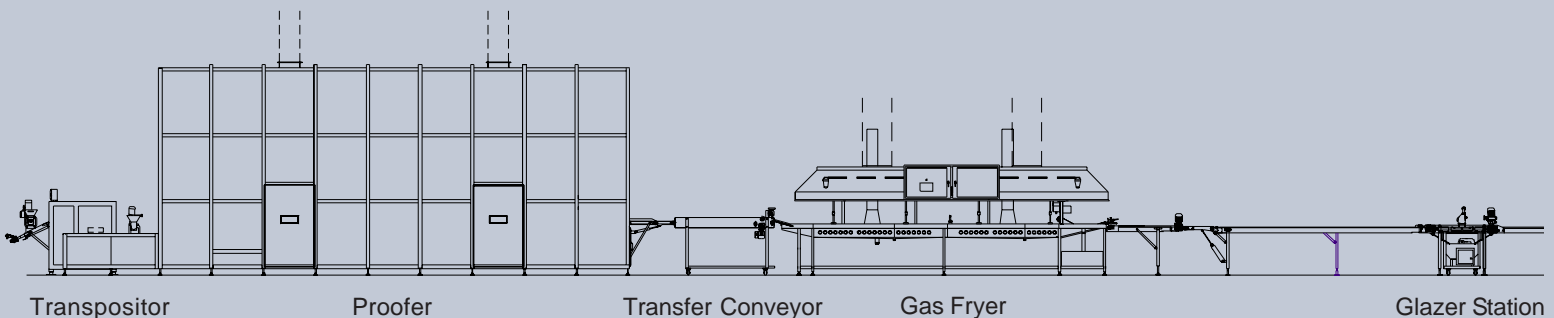

Due to the Moline policy of continuous improvement, specifications are subject to change without notice.