

Moline Gas Fryers



Combining cutting edge technology with efficient sanitation for continuous high-volume production.



The DonutKing Depositor/Gas Fryer combination shown above is only one of many equipment options available from Moline.

Moline gas fryers are custom designed to provide durability, low maintenance and easy cleanup for maximum production.

Moline gas fryers are fully automated, BISSC certified and designed to suit a wide range of continuous production requirements. Production capacities are the highest in the industry, ranging from 400 to 4500 dozen per hour.

The industrial design of these fryers is renowned for durability, reliability and efficiency. Controls are centrally located and easy to use for efficient and consistent production.

Moline also provides dependable service "after the sale". Qualified factory-trained technicians provide on-site supervision as the equipment is uncrated, positioned and assembled. The modular design assures fast and precise installation. Mechanical settings are adjusted, product testing is conducted along with operator training to fine tune production methods. Our commitment to safety, reliability and value has made us a leader in baking equipment for well over half a century. Call our Customer Service Department for more information.



Moline Machinery LLC

114 South Central Avenue • Duluth, Minnesota, USA, 55807
218-624-5734 (For after hours service, call 218-590-1987)
www.moline.com • sales@moline.com

Gas Fryer Features

Gas Fryer Features:

- Modular stainless steel exhaust canopy fits directly on the fryer frame - no ceiling supports required.
- Stainless steel main conveyor (surface conveyor) assembly with ball screw lift mechanism is designed to lift the conveyor from the kettle with the touch of a button. Limits are provided to prevent over-travel.
- The variable speed main conveyor drive system allows frying times from 60 to 360 seconds. A pneumatic torque

- limiter (easily reset) helps to prevent damage should an overload occur.
- The equipment is controlled through an operator interface mounted on the fryer (styles vary). Electronically synchronized product delivery into the main conveyor flight pockets provides accurate and efficient product placement.

Fryer In-line Product Turner



The product turner, located at the center of the fryer, includes single-lever control to easily adjust for product size. The optional product positioning air system assists smooth product turnover.

Beneficial Sanitation Features:

- Sealed kettle frame (no openings to the inside) and sediment sumps for improved sanitation.
- The kettle, shortening holding tank, exhaust canopy and exhaust manifolds are constructed of stainless steel. Components that are not stainless are constructed of noncorrosive metals for thorough sanitation. Crevices and hard-to-clean areas have been eliminated.
- Sanitary adjustable legs.
- Canopy contains easily accessed filters.
- Exhaust manifolds are easily dismantled for cleaning.

Optional Equipment:

- Turbulence system (helps to reduce side-to-side temperature differential on wide fryers. Provides improved continuous filter operation, extending operating time between boil-outs).
- Remote electrical control panel (keeps controls and electrical components away from the fryer for more efficient fryer sanitation).
- UL and CE approvals.
- Fire protection system.
- Canopy lighting (illuminates fryer operations from under the canopy).
- Canopy side shields (provide protection from frying oil).
- Canopy exhaust blowers (aid in removing residual vapors).
- Product flip conveyor (flips product at fryer discharge).
- Submergers (controls product submersion during frying).
- Product-positioning air systems (help control product position in the fryer during production).
- Portable shortening supply tank.

Fryer Control Panels



Articulating Arm Style



Canopy Mounted Style

Several fryer control panel styles are available, each with an easy-to-use operator interface touch screen that includes electronic control buttons and graphs for monitoring fryer temperature. Several panel locations are available including articulating, canopy mounted, kettle mounted and remote mounted.

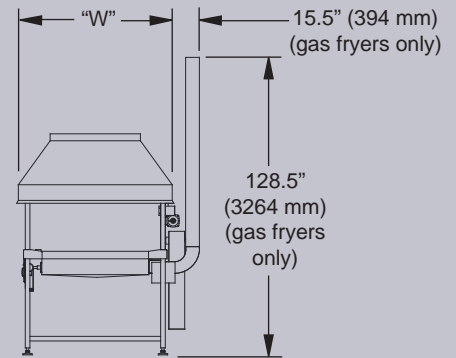
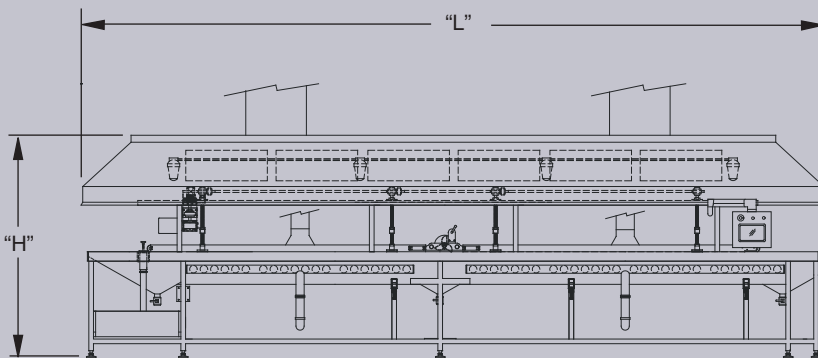

Left hand fryer is shown.

See "Overall Dimensions" in specification table on the following page for corresponding sizes to dimensions shown above.



Moline Gas Fryers

Gas Frying System Features

Heating System:

- Flared burner tubes for improved strength and sanitation. The "Cold Zone" design helps to lengthen shortening life.
- Gas fired with independent pre-mixers for maximum safe heat transfer with positive and complete combustion.
- Quick heat recovery by means of pre-mix gas system to accommodate all types and sizes of fried product.

Electrical System:

- Standard Electrical: 240 or 480 Volt, 60 Hertz, 3 Phase.

Flue Exhaust:

- Draft inducers interlocked with ignition system.
- Stainless steel flue stacks with barometric dampers.

Optional Equipment:

- Remote gas plumbing module removes gas plumbing components from washdown area for efficient fryer sanitation.

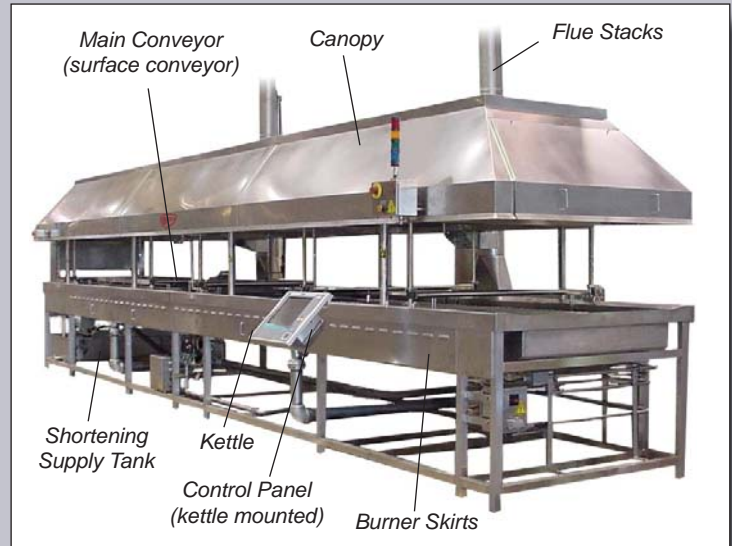

Fryer Model	Productivity (with 3-3/4" flights and 90 second fry time)	Overall Dimensions (see drawing on page 2 for corresponding dimensions)	Active Flights			Estimated Shortening Capacity lbs (kg)	Air	Canopy Exhaust	Flue Exhaust
			3-3/4" (95 mm) flight spacing	4-3/8" (111 mm) flight spacing	5" (127 mm) flight spacing				
GF12-8S	840 Doz/Hr (8 Cutters)	L = 13' 0" (3962 mm) W = 4' 11" (1499 mm) H = 8' 0" (2438 mm)	31.5	27	24	1150 lbs (522 kg)	20 CFM @ 5 to 10 PSI (9.44 Liters/Second @ .69 BAR) Clean, dry, oil free air. Regulated connection to fryer by customer.	22" (559 mm). 1 opening.	Stack installation and connection by customer.
GF16-8S	1186 Doz/Hr (8 Cutters)	L = 17' 0" (5182 mm) W = 4' 11" (1499 mm) H = 8' 0" (2438 mm)	44.5	38	33.5	1627 lbs (738 kg)		22" (559 mm). 2 openings.	
GF16-10S	1483 Doz/Hr (10 Cutters)	L = 17' 0" (5182 mm) W = 5' 7" (1702 mm) H = 8' 0" (2438 mm)	44.5	38	33.5	1970 lbs (894 kg)			
GF20-10S	1900 Doz/Hr (10 Cutters)	L = 21' 0" (6401 mm) W = 5' 7" (1702 mm) H = 8' 0" (2438 mm)	59	49	43	2320 lbs (1052 kg)			
GF22-8S	1693 Doz/Hr (8 Cutters)	L = 23' 0" (7010 mm) W = 4' 11" (1499 mm) H = 8' 0" (2438 mm)	63.5	54.5	48	2420 lbs (1098 kg)			
GF22-10S	2117 Doz/Hr (10 Cutters)	L = 23' 0" (7010 mm) W = 5' 7" (1702 mm) H = 8' 0" (2438 mm)	63.5	54.5	48	2930 lbs (1329 kg)			
GF26-10S	2500 Doz/Hr (10 Cutters)	L = 26' 6" (8077 mm) W = 5' 7" (1702 mm) H = 8' 0" (2438 mm)	75	64	56	3440 lbs (1560 kg)			
GF28-10S	2683 Doz/Hr (10 Cutters)	L = 28' 4" (8637 mm) W = 5' 7" (1702 mm) H = 8' 0" (2438 mm)	80.5	69	60.5	4142 lbs (1879 kg)			
GF30-10S	2900 Doz/Hr (10 Cutters)	L = 30' 4" (9246 mm) W = 5' 7" (1702 mm) H = 8' 0" (2438 mm)	87	74.5	65	4740 lbs (2150 kg)			
GF32-10S	3116 Doz/Hr (10 Cutters)	L = 32' 4" (9855 mm) W = 5' 7" (1702 mm) H = 8' 0" (2438 mm)	93.5	80	70	5340 lbs (2422 kg)			



Moline Gas Fryers

Auxiliary Frying System Equipment

Moline Frying Systems include many other equipment options as listed below. For more information on these individual components, call the Moline Customer Service Department at 218-624-5734 or email us at sales@moline.com.

Frying System Equipment Options

- DonutKing Cake Donut Depositor
- MD81 Pressure Depositor
- Yeast Raised Pressure Depositor
- Automatic Proofer
- Conveyor Systems
- Glazer Station
- Icer/Glazer Station
- Glazer/Crumber Unit
- SugarKing Sugaring Machine
- Transpositor (for proofer loading)

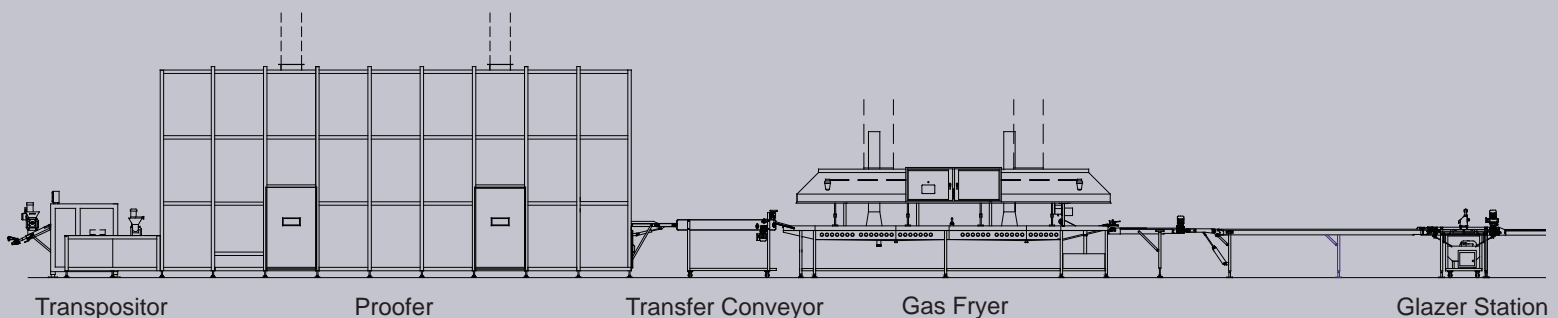
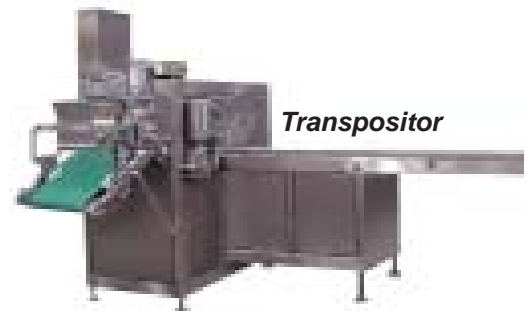

Due to the Moline policy of continuous improvement, specifications are subject to change without notice.



Moline Gas Fryers