

# The Moline Penta-Roll Extruder



*Designed to handle moist, very thick doughs efficiently and consistently.*



- *Provides low stress processing for high moisture and very thick doughs.*
- *Sizes are available to suit production systems from 24" to 60" wide.*
- *Designed for high capacity at 20,000 lbs. of dough per hour, depending upon the application.*
- *Designed for easy and efficient sanitation.*

*The penta-roll extruder provides low stress processing of very thick, high moisture doughs. The extruder contains five rollers. This combination provides consistent, low stress processing without overworking the dough, leaving cell structure open and loose. The extruder is manufactured in several sizes to produce dough sheets from 16" to 32" wide, at 2" thick or more. Typical production rate is 20,000 pounds per hour depending upon the application.*

*Dough is fed into the extruder hopper from a dough delivery system. From the hopper, the dough travels*

*down between the fine and heavy-groove rollers to the lower extruding roller where it is formed into a continuous sheet and delivered to the sheeting system. The lower roller opening controls dough sheet thickness and is easily adjusted with the hand wheel located on the front of the extruder.*

*The extruder hopper is available in several sizes and heights to suit many different types of systems. Lexan windows in the hopper allow electronic dough level monitoring and synchronization when the extruder is used with a Moline starwheel chunker.*



## **Moline Machinery LLC**

114 South Central Avenue • Duluth, Minnesota, USA, 55807  
218-624-5734 (For after hours service, call 218-590-1987)  
www.moline.com • sales@moline.com



# The Moline Penta-Roll Extruder

## Extruder Features

- **Construction:**  
Heavy-gauge stainless steel construction with precision machined components. Mounted on casters for portability.
- **Guards and Covers:**  
Safety interlocked guards and hopper prevent access to rollers during operation.
- **Control Functions:**  
Roller speeds are easily adjusted through the operator interface.
- **Drive System:**  
Standard configuration includes four drive motors for complete control.
- **Dough Delivery System:**  
When used with a Moline starwheel chunker, synchronized delivery is provided with portioned dough chunks to maintain a constant level in the extruder hopper. This system greatly improves final product weight control.

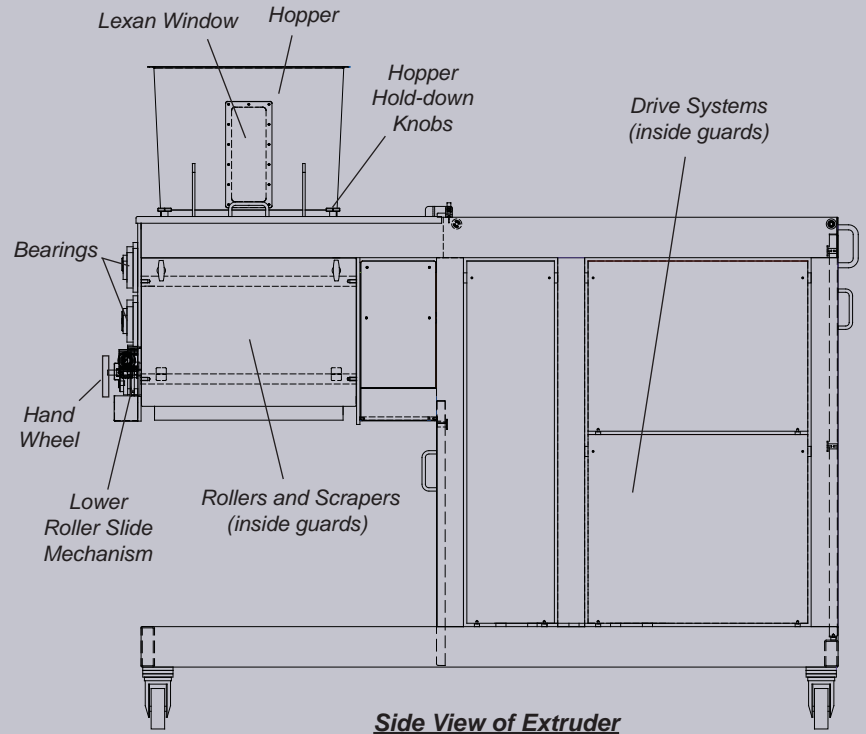

**Moline Penta-Roll Extruder**

Due to continuous product improvement, specifications are subject to change without notice.

Bulletin 767 051711