

Moline

Tri-Roll Extruders



Designed to extrude thick and stiff doughs quickly, efficiently and consistently.

The Moline tri-roll extruder provides the ability to process thick, stiff and high moisture doughs. The extruder contains two different grooved upper rollers, plus a lower or "print" roller. This combination provides consistent processing without overworking the dough, leaving cell structure open and loose. The extruder is manufactured in several configurations and sizes to produce dough sheets from 18" to 60" wide, with a maximum thickness of 1-3/4".

Dough is fed into the extruder hopper from a dough

delivery system (typically a Moline starwheel chunker). From the hopper, the dough travels down between the upper rollers to the lower roller where it is formed into a continuous sheet and delivered to the sheeting system. The lower roller opening controls dough sheet thickness and is easily adjusted with the hand wheel located on the front of the extruder.

The tri-roll extruder can be designed to integrate with other Moline equipment such as the starwheel chunker and sheeting systems.

Tri-Roll Extruder
(Short Profile)



- **Provides efficient processing for stiff, thick and/or moist doughs.**
- **Sizes are available to suit production systems from 18" to 60" wide.**
- **Maximum capacity is 20,000 lbs. of dough per hour, depending upon the application.**
- **Portable for easy removal from the production line when not in use.**



Moline Machinery LLC

114 South Central Avenue • Duluth, Minnesota, USA, 55807
218-624-5734 (For after hours service, call 218-590-1987)
www.moline.com • sales@moline.com



Moline Tri-Roll Extruder

Extruder Features

- Construction:**
 Heavy-gauge stainless steel construction with precision machined components. Mounted on casters for portability.
- Guards and Covers:**
 Safety interlocked hopper and guards prevent access to rollers during operation but allow efficient access for inspection, sanitation and maintenance during machine shutdown.
- Control Functions:**
 Roller speeds are easily adjusted through the system operator interface or local control panel. Roller opening is adjusted with the hand wheel at the front of the machine.
- Drive System:**
 Maximum of two 10 hp motors and reducers.
- Dough Delivery System:**
 When used with a Moline starwheel chucker, synchronized delivery is provided with portioned dough chunks to maintain a constant level in the extruder hopper. This system greatly improves final product weight control.

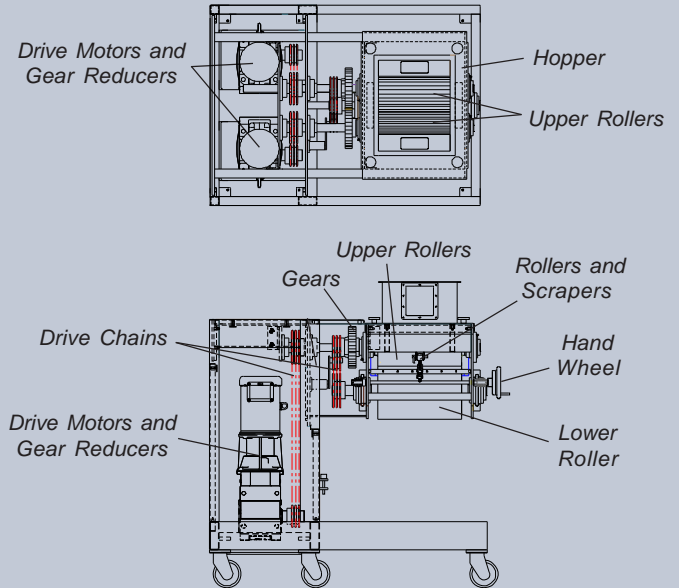

Upper Rollers Beneath Hopper

Other Extruder Styles

The long profile tri-roll extruder provides efficient extrusion of very stiff, heavy doughs for wider lines. The unit contains horizontal roller drives and chain/gear-driven rollers.

The H-frame tri-roll extruder provides fast and efficient dough extrusion for very wide lines with a portable and stable design. The unit contains vertical roller drives and chain/gear-driven rollers.



Long Profile Tri-Roll Extruder



H-Frame Tri-Roll Extruder



Moline Tri-Roll Extruders

Due to continuous product improvement, specifications are subject to change without notice.

Bulletin 785 091508