

Moline Dough Plows and Repositioners



Providing controlled and accurate dough folding and positioning.

Dough Plows

Moline dough plows are a versatile answer for dough strip folding and sealing after a filling or topping has been applied. Each provides controlled and accurate processing whether powered or non-powered and can be raised or removed from the production area when not in use. All contain stainless steel frames and components and are controlled either manually or through the production system's operator interface. The units can accommodate conveyor widths of 24" - 60".

Round Dough Plows

The round dough plow contains a 1" diameter Delrin plow with an adjustable UHMW sealing cone and a counterweight for adjusting plow pressure. Several plows can be installed on one frame and each is adjustable for both angle of contact with the dough and position across the conveyor bed. An accessory latch or clamp mounting system is included.

Dough thickness range: 1/8" (3 mm) min. - 3/8" (10 mm) max.
Maximum dough to be plowed: 1-1/2" (38 mm).

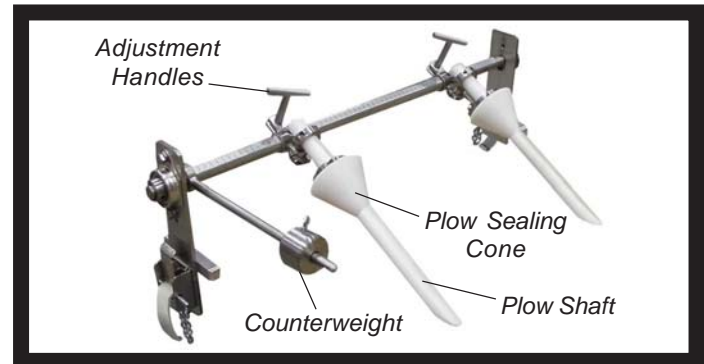

Round Dough Plow

Flat Dough Plows

The flat plow contains 2-1/2" (64 mm) or 3-1/2" (89 mm) wide stainless steel plows (Teflon-coated plows for sticky doughs are optional). Several plows can be installed on one frame and each is adjustable across the width of the conveyor bed. An accessory latch or clamp mounting system is included.

Dough thickness range: 1/8" (3 mm) min. - 3/8" (10 mm) max.
Maximum dough to be plowed: 4" (102 mm).

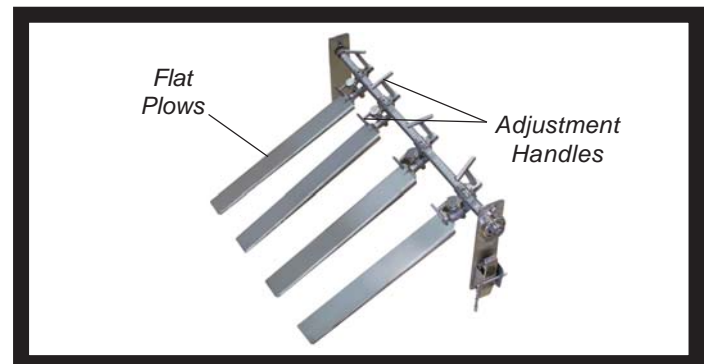

Flat Dough Plow

Powered Flat Dough Plows

The powered flat plow is used for thicker doughs and contains two stainless steel plows with USDA/FDA approved neoprene belts driven by a gearmotor. Each plow can be raised from the conveyor bed when not in use. Accessory latch or rail mounting system is included.

Dough thickness range: 1/8" (3 mm) min. - 1" (25 mm) max.
Maximum dough to be plowed: 8" (204 mm).

Standard electrical requirements:

230/480 Volts, 60 Hertz, 3 Phase (others options available).

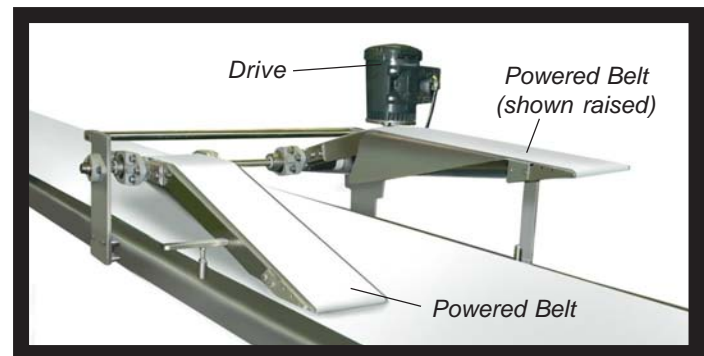

Powered Flat Dough Plow



Moline Machinery LLC

114 South Central Avenue • Duluth, Minnesota, USA, 55807
218-624-5734 (For after hours service, call 218-590-1987)
www.moline.com • sales@moline.com



Moline Dough Plows and Repositioners

Repositioners

Moline repositioners, whether roller or paddle style, are used to align curled dough for further processing downstream and to reshape it into a more circular dough “snake”. All contain stainless steel frames and components and are controlled either manually or through the production system’s operator interface. The rollers and paddles can be raised or removed from the production area when not in use. The units can accommodate conveyor widths of 24” - 60”.

Powered Roller-Style Repositioners

The powered roller repositioner is used for slight shifts in positioning and for reshaping the curled dough into a round dough “snake”. The UHMW rollers are independently driven and several can be installed on one frame. Each roller assembly is magnetized, providing full adjustment across the conveyor width by simply sliding them where desired on the frame. Accessory latch or clamp mounting system is included; larger units are mounted directly to the conveyor rail for maximum stability.

Standard electrical requirements:

115 Volts, 60 Hertz, 1 Phase (others options available).

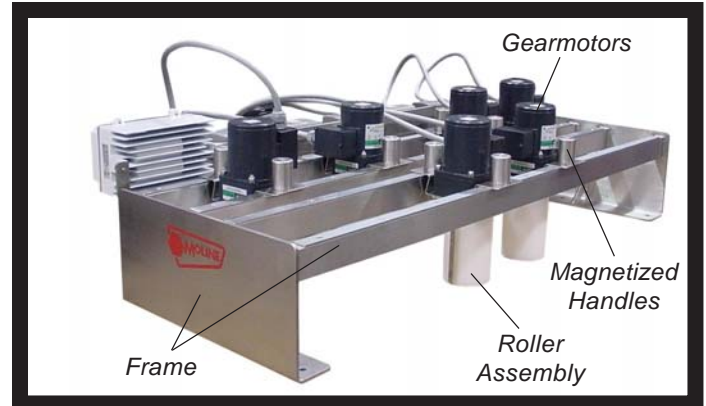

Powered Roller-Style Repositioner

Powered Paddle-Style Repositioners

The paddle-style repositioner is used to reposition the dough snake where required on the conveyor. Each stainless steel paddle pulses against the dough snake to move it into position. The paddles are powered by one gearmotor mounted to the repositioner frame. Each paddle is individually adjustable for both angle and position across the width of the conveyor.

Standard electrical requirements:

115 Volts, 60 Hertz, 1 Phase (others options available).

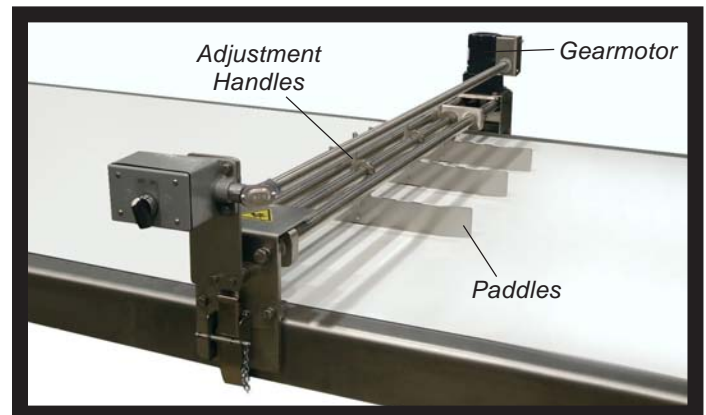

Powered Paddle-Style Repositioner

Paddle-Style Repositioner (non-powered)

The non-powered paddle repositioner positions the dough snake where required on the conveyor bed with stationary stainless steel paddles. The paddles are individually adjustable for both angle and position across the width of the conveyor bed. An accessory latch or clamp mounting system is included.

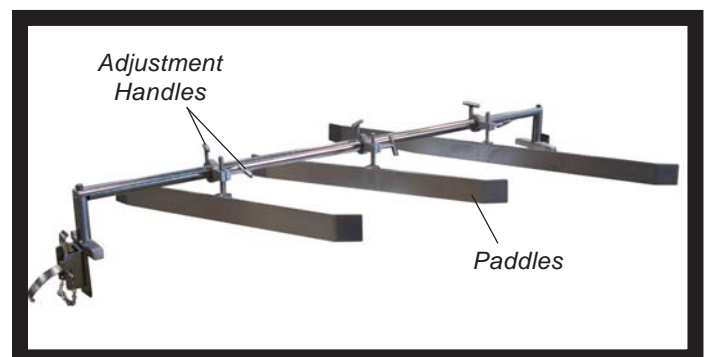

Paddle-Style Repositioner (non-powered)