

Moline Cake Donut Cutters



Providing Durability and Efficiency With Every Cut.

Moline cake donut cutters are available in a variety of styles to cut specific donut shapes efficiently and uniformly. Installed in a Moline DonutKing Depositor or Belshaw Depositor, the durable design of the cutters provides reliable and continuous service.

During operation, the plunger slides up and down through the forming cylinder, cutting batter into product with each plunger cycle. The depositor must have a compatible cylinder plate (also sold separately) for the type of cutter to be used.

Cutter assemblies are stainless steel and consist of a plunger, a forming cylinder and a cylinder clamp (each component is sold separately).

Cutter assemblies are easy to remove from the depositor and can be quickly disassembled for sanitation.

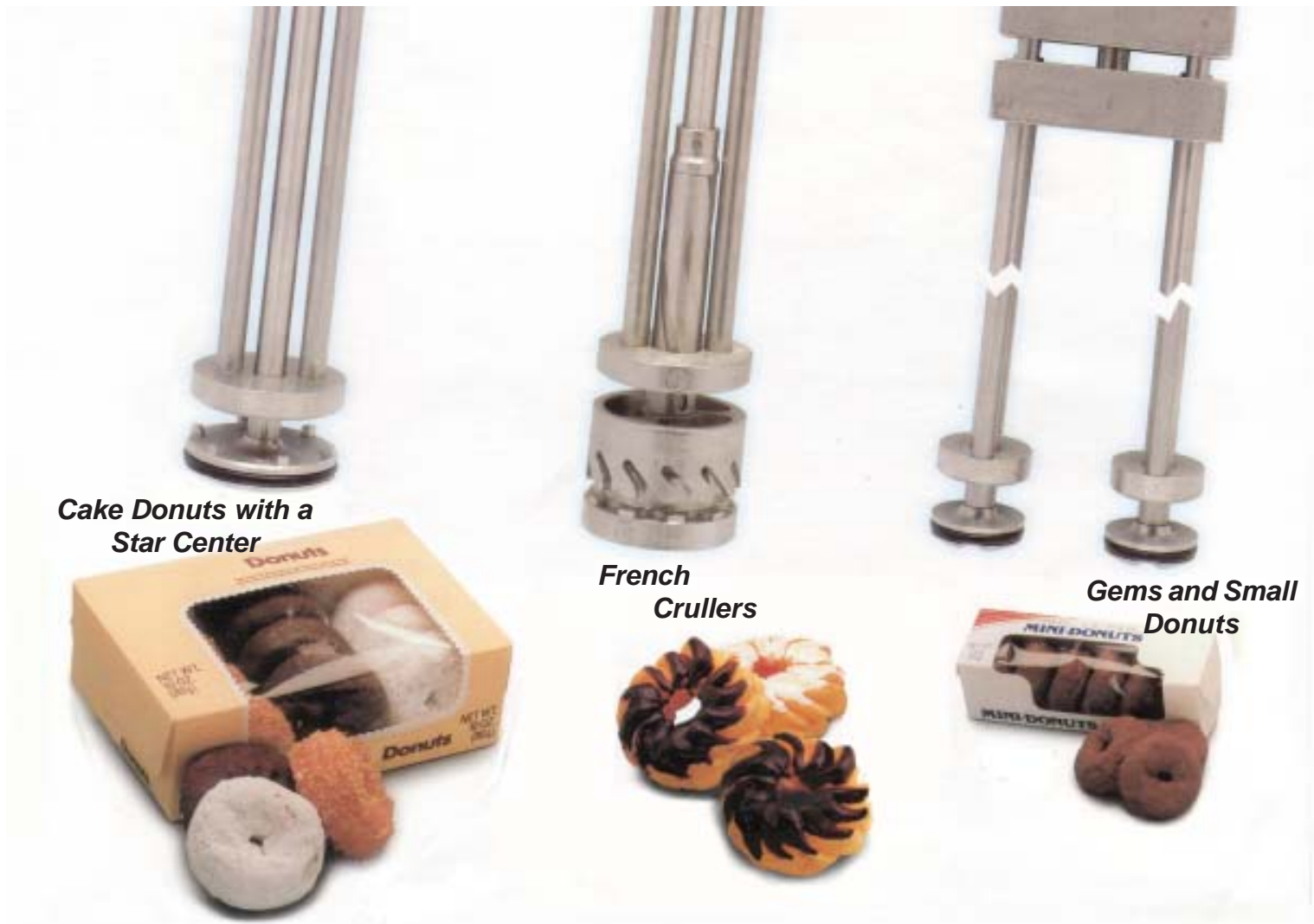

Cake Donuts with a Star Center

French Crullers

Gems and Small Donuts



Moline Machinery LLC

114 South Central Avenue • Duluth, Minnesota, USA, 55807
218-624-5734 (For after hours service, call 218-590-1987)
www.moline.com • sales@moline.com

Cutter Assemblies



Maximum Efficiency and Flexibility in Cake Donut Cutting

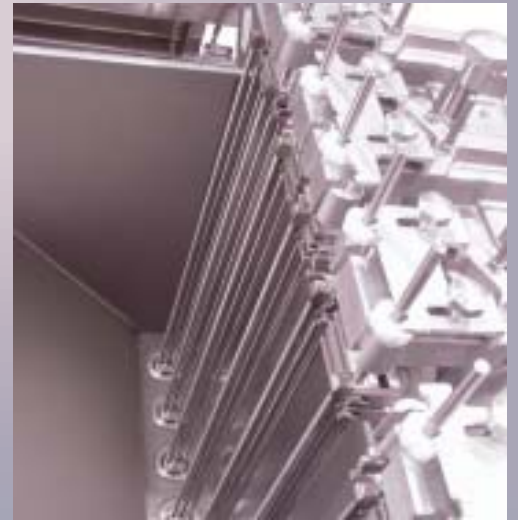

Cutter / Donut Size Table

Plunger/ Cylinder Dia. (d)	* Approx. Raw Wt./Piece		* Approx. Fried Wt./Piece		Approx. Fried Size O.D.	
	ounces	grams	ounces	grams	inches	mm
7/8"	.25	7	.32	9	1	25
1"	.38	11	.48	14	1-1/4	32
1-1/8"	.50	14	.62	18	1-3/8	35
1-1/4"	.65	18	.80	23	1-1/2	38
1-3/8"	.80	23	1.00	28	1-5/8	41
1-1/2"	.95	27	1.18	33	1-7/8	48
1-5/8"	1.10	31	1.38	39	2-1/4	57
1-3/4"	1.25	35	1.56	44	2-5/8	67
1-7/8"	1.50	43	1.88	53	3	76
2"	1.75	50	2.18	62	3-3/8	86
2-1/8"	2.00	57	2.50	70	3-3/4	95
2-1/4"	2.25	64	2.80	79	4-1/8	105

* Weight range is approximately -5% for donuts with Star plungers and +5% for donuts with Plain plungers.

Plain Donut Cutter

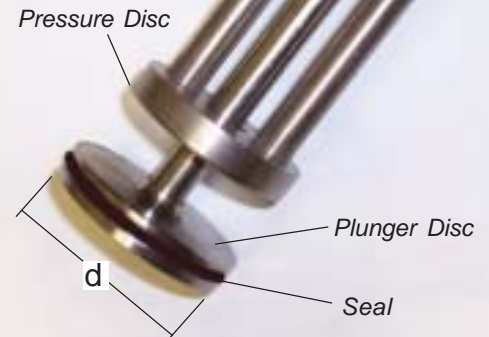

Durable stainless steel plungers available in a variety of shapes and sizes.

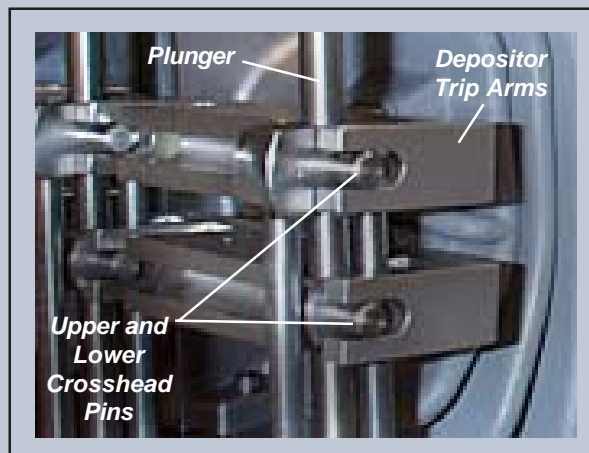

Cake Donut Cutters

Plunger Styles and Sizes

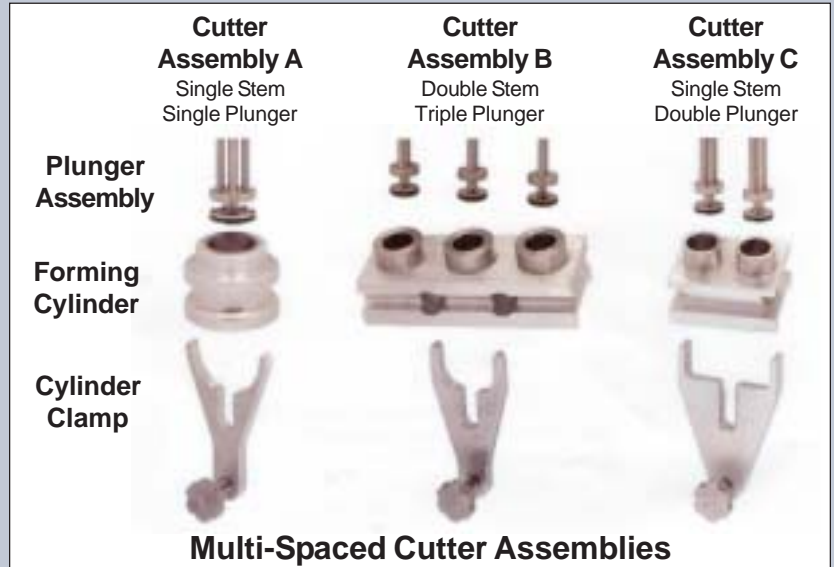
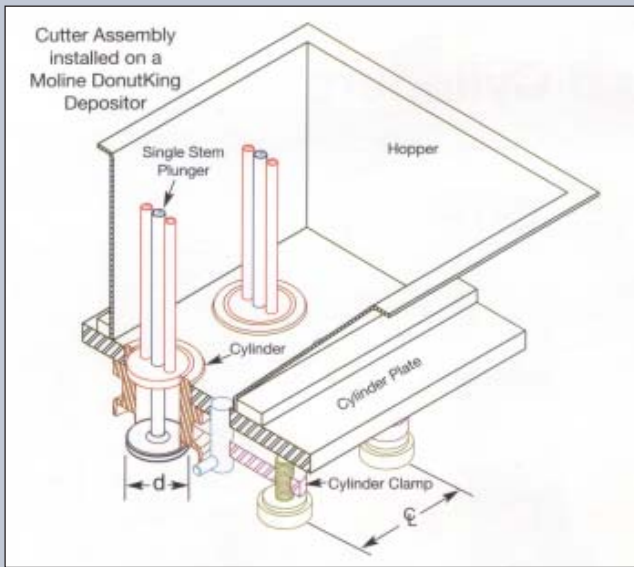

Plunger Style →	Plain				Star				French				Mini			
		Sizes Available for Plunger Dia. (d) in 1/8" Increments														
Depositor Configuration	Min.	Max.	Assy.	Min.	Max.	Assy.	Min.	Max.	Assy.	Assy.						
Belshaw MD, MDD	3.75 ¢	7/8	2-1/4	A	7/8	2-1/4	A	1-1/8	2-1/4	A	Use Plain or Star Plungers in 7/8" or 1" diameter.					
	1.88 ¢	7/8	1	C	7/8	1	C		N/A							
Moline DonutKing	4.00 ¢	7/8	2-1/4	A	7/8	2-1/4	A	1-1/8	2-1/4	A						
MC/MS	3.20 ¢	7/8	1-7/8	A	7/8	1-7/8	A	1-1/8	1-7/8	A						
and	2.67 ¢	7/8	1-1/2	B	7/8	1-1/2	B		N/A							
Belshaw MS, MSPF	2.00 ¢	7/8	1-1/8	C	7/8	1-1/8	C		N/A							

Plunger Style →	Ball/Hole			Bar/Stick			Krinkle			Old Fashioned			
		Sizes Available for Plunger Dia. (d) in 1/8" Increments											
Depositor Configuration	Min.	Max.	Assy.	Min.	Max.	Assy.	Min.	Max.	Assy.	Min.	Max.	Assy.	
Belshaw MD, MDD	3.75 ¢	1-1/2	2-1/4	A	1-1/2	2-1/4	A	1-1/2	2	A	1-1/2	2-1/4	A
	1.88 ¢		N/A			N/A		N/A			N/A		
Moline DonutKing	4.00 ¢	1-1/2	2-1/4	A	1-1/2	2-1/4	A	1-1/2	2	A	1-1/2	2-1/4	A
MC/MS	3.20 ¢	1-1/2	1-7/8	A	1-1/2	1-7/8	A	1-1/2	1-7/8	A	1-1/2	1-7/8	A
and	2.67 ¢		N/A			N/A		N/A			N/A		
Belshaw MS, MSPF	2.00 ¢		N/A			N/A		N/A			N/A		
	Specify 2, 3 or 4 Holes			Specify 1 or 2 Holes									

Due to the Moline policy of continuous improvement, specification are subject to change without notice.



Cake Donut Cutters